

# 100Gb/s QSFP28 ER4 Transceiver

## Features

- Compliant to Ethernet 100GBASE-ER4
- Supports 103.125Gb/s aggregate bit rate
- Transmitter: cooled 4x25Gb/s LAN WDM TOSA (1295.56, 1300.05, 1304.58, 1309.14nm)
- Receiver: 4x25Gb/s APD ROSA
- Up to 40km reach for G.652 SMF
- Built-in 4-channel Clock and Data Recovery (CDR) in TX and RX
- Duplex LC optical receptacle
- 4x25G electrical interface (OIF CEI-28G-VSR)
- RoHS-10 compliant and lead-free
- Single +3.3V power supply
- Maximum power consumption 4.5W
- Case operating temperature  
Commercial: 0 ~ +70°C  
Extended: -5 ~ +85°C  
Industrial: -40 ~ +85°C



## Applications

- 100GBASE-ER4 Ethernet Links
- Infiniband QDR and DDR interconnects
- Client-side 100G Telecom connections

## Part Number Ordering Information

Part Number	Data Rate (Gb/s)	Wavelength (nm)	Transmission Distance(km)	Temperature (°C) (Operating Case)
FBL4-ER040C	103.125	1295.56, 1300.05, 1304.58, 1309.14	40	0~70
FBL4-ER040E	103.125	1295.56, 1300.05, 1304.58, 1309.14	40	-5~85
FBL4-ER040I	103.125	1295.56, 1300.05, 1304.58, 1309.14	40	-40~85

## I. Absolute Maximum Ratings

It has to be noted that the operation in excess of any individual absolute maximum ratings might cause permanent damage to this module.

Parameter	Symbol	Min	Max	Unit	Notes
Storage Temperature	T <sub>S</sub>	-40	85	°C	
Power Supply Voltage	V <sub>CC</sub>	-0.3	4.0	V	
Relative Humidity (non-condensation)	RH	0	85	%	
Damage Threshold	TH <sub>d</sub>	-3.0		dBm	

## II. Recommended Operating Conditions

Parameter	Symbol	Min	Typical	Max	Unit	Notes
Operating Case Temperature	T <sub>OP</sub>	0		70	°C	Commercial
		-5		85		Extended
		-40		85		Industrial
Power Supply Voltage	V <sub>CC</sub>	3.135	3.3	3.465	V	
Data Rate, each Lane			25.78125		Gb/s	
Control Input Voltage High		2		V <sub>CC</sub>	V	
Control Input Voltage Low		0		0.8	V	
Link Distance (SMF)	D			40	km	1

Notes:

1. Depending on actual fiber loss/km (link distance specified is for fiber insertion loss of 0.35dB/km)

## III. General Description

This product is a 100Gb/s transceiver module designed for optical communication applications compliant to Ethernet 100GBASE-ER4 standard. The module converts 4 input channels of 25Gb/s electrical data to 4 channels of LAN WDM optical signals and then multiplexes them into a single channel for 100Gb/s optical transmission. Reversely on the receiver side, the module de-multiplexes a 100Gb/s optical input into 4 channels of LAN WDM optical signals and then converts them to 4 output channels of electrical data.

The central wavelengths of the 4 LAN WDM channels are 1295.56, 1300.05, 1304.58 and 1309.14 nm as members of the LAN WDM wavelength grid defined in IEEE 802.3ba. The high-performance cooled LAN WDM DFB transmitters and high sensitivity APD receivers provide superior performance for 100Gigabit Ethernet applications up to 40km links.

The product is designed with form factor, optical/electrical connection and digital diagnostic interface according to the QSFP+ Multi-Source Agreement (MSA). It has been designed to meet the harshest external operating conditions including temperature, humidity and EMI interference.

## IV. Functional Description

The transceiver module receives 4 channels of 25Gb/s electrical data, which are processed by a 4-channel Clock and Data Recovery (CDR) IC that reshapes and reduces the jitter of each electrical signal. Subsequently, DML laser driver IC converts each one of the 4 channels of electrical signals to an optical signal that is transmitted from one of the 4 cooled DML lasers which are packaged in the Transmitter Optical Sub-Assembly (TOSA). Each laser launches the optical signal in specific wavelength specified in IEEE 802.3ba 100GBASE-ER4 requirements. These 4-lane optical signals will be optically multiplexed into a single fiber by a 4-to-1 optical WDM MUX. The optical output power of each channel is maintained constant by an automatic power control (APC) circuit. The transmitter output can be turned off by TX\_DIS hardware signal and/or 2-wire serial interface.

The receiver receives 4-lane LAN WDM optical signals. The optical signals are de-multiplexed by a 1-to-4 optical DEMUX and each of the resulting 4 channels of optical signals is fed into one of the 4 receivers that are packaged into the Receiver Optical Sub-Assembly (ROSA). Each receiver converts the optical signal to an electrical signal. The regenerated electrical signals are retimed and de-jittered and amplified by the RX portion of the 4-channel CDR. The retimed 4-lane output electrical signals are compliant with CEI-28G-VSR interface requirements. In addition, each received optical signal is monitored by the DOM section. The monitored value is reported through the 2-wire serial interface. If one or more received optical signal is weaker than the threshold level, RX\_LOS hardware alarm will be triggered.

A single +3.3V power supply is required to power up this product. Both power supply pins VccTx and VccRx are internally connected and should be applied concurrently. As per MSA specifications the module offers 7 low speed hardware control pins (including the 2-wire serial interface): ModSelL, SCL, SDA, ResetL, LPMode, ModPrsL and IntL.

Module Select (ModSelL) is an input pin. When held low by the host, this product responds to 2-wire serial communication commands. The ModSelL allows the use of this product on a single 2-wire interface bus – individual ModSelL lines must be used.

Serial Clock (SCL) and Serial Data (SDA) are required for the 2-wire serial bus communication interface and enable the host to access the QSFP28 memory map.

The ResetL pin enables a complete reset, returning the settings to their default state, when a low level on the ResetL pin is held for longer than the minimum pulse length. During the execution of a reset the host shall disregard all status bits until it indicates a completion of the reset interrupt. The product indicates this by posting an IntL (Interrupt) signal with the Data\_Not\_Ready bit negated in the memory map. Note that on power up (including hot insertion) the module should post this completion of reset interrupt without requiring a reset.

Low Power Mode (LPMode) pin is used to set the maximum power consumption for the product in order to protect hosts that are not capable of cooling higher power modules, should such modules be accidentally inserted.

Module Present (ModPrsL) is a signal local to the host board which, in the absence of a product, is

normally pulled up to the host Vcc. When the product is inserted into the connector, it completes the path to ground through a resistor on the host board and asserts the signal. ModPrsL then indicates its present by setting ModPrsL to a “Low” state.

Interrupt (IntL) is an output pin. “Low” indicates a possible operational fault or a status critical to the host system. The host identifies the source of the interrupt using the 2-wire serial interface. The IntL pin is an open collector output and must be pulled to the Host Vcc voltage on the Host board.

## V. Pin Assignment and Pin Description

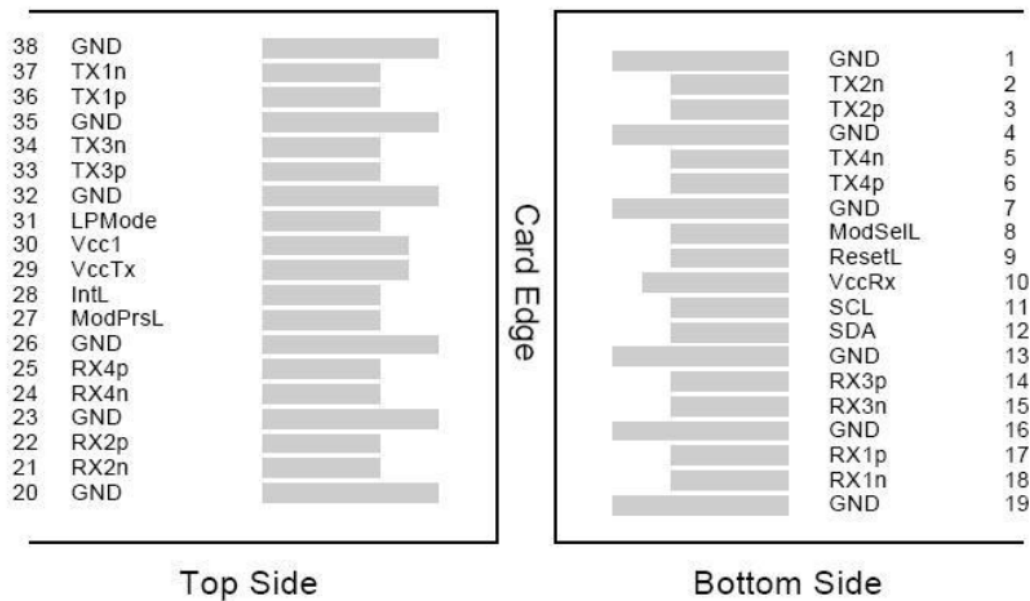

Figure1. Diagram of host board connector block pin numbers and names

Pin	Symbol	Name/Description	Notes
1	GND	Transmitter Ground (Common with Receiver Ground)	1
2	Tx2n	Transmitter Inverted Data Input	
3	Tx2p	Transmitter Non-Inverted Data output	
4	GND	Transmitter Ground (Common with Receiver Ground)	1
5	Tx4n	Transmitter Inverted Data Input	
6	Tx4p	Transmitter Non-Inverted Data output	
7	GND	Transmitter Ground (Common with Receiver Ground)	1
8	ModSelL	Module Select	

9	ResetL	Module Reset	
10	VccRx	3.3V Power Supply Receiver	2
11	SCL	2-Wire serial Interface Clock	
12	SDA	2-Wire serial Interface Data	
13	GND	Transmitter Ground (Common with Receiver Ground)	
14	Rx3p	Receiver Non-Inverted Data Output	
15	Rx3n	Receiver Inverted Data Output	
16	GND	Transmitter Ground (Common with Receiver Ground)	1
17	Rx1p	Receiver Non-Inverted Data Output	
18	Rx1n	Receiver Inverted Data Output	
19	GND	Transmitter Ground (Common with Receiver Ground)	1
20	GND	Transmitter Ground (Common with Receiver Ground)	1
21	Rx2n	Receiver Inverted Data Output	
22	Rx2p	Receiver Non-Inverted Data Output	
23	GND	Transmitter Ground (Common with Receiver Ground)	1
24	Rx4n	Receiver Inverted Data Output	1
25	Rx4p	Receiver Non-Inverted Data Output	
26	GND	Transmitter Ground (Common with Receiver Ground)	1
27	ModPrsl	Module Present	
28	IntL	Interrupt	
29	VccTx	3.3V power supply transmitter	2
30	Vcc1	3.3V power supply	2
31	LPMode	Low Power Mode	
32	GND	Transmitter Ground (Common with Receiver Ground)	1
33	Tx3p	Transmitter Non-Inverted Data Input	
34	Tx3n	Transmitter Inverted Data Output	
35	GND	Transmitter Ground (Common with Receiver Ground)	1

36	Tx1p	Transmitter Non-Inverted Data Input	
37	Tx1n	Transmitter Inverted Data Output	
38	GND	Transmitter Ground (Common with Receiver Ground)	1

Notes:

1. GND is the symbol for signal and supply (power) common for QSFP28 modules. All are common within the QSFP28 module and all module voltages are referenced to this potential unless otherwise noted. Connect these directly to the host board signal common ground plane.
2. VccRx, VccI and VccTx are the receiving and transmission power suppliers and shall be applied concurrently. Recommended host board power supply filtering is shown below. Vcc Rx, VccI and Vcc Tx may be internally connected within the QSFP28 transceiver module in any combination. The connector pins are each rated for a maximum current of 1000mA.

## VI. Electrical Characteristics

The following electrical characteristics are defined over the Recommended Operating Environment unless otherwise specified.

Parameter	Symbol	Min.	Typ.	Max	Unit	Notes
Power Consumption	p			4.5	W	
Supply Current	Icc			1360	mA	
<b>Transmitter (each Lane)</b>						
Input differential impedance	Rin		100		$\Omega$	
Differential Termination Mismatch				10	%	
Differential Data Input Amplitude	Vin, PP	180		1000	mV	
LPMode, Reset and ModSelL	VIL	-0.3		0.8	V	
	VIH	2		Vcc+0.3	V	
<b>Receiver</b>						
Differential Data Output Amplitude	Vout, PP	350		900	mV	
Differential Termination Mismatch				10	%	
Transition Time, 20 to 80%		9.5			ps	
ModPrsL and IntL	VOL	0		0.4	V	
	VOH	Vcc-0.5		Vcc+0.3	V	

## VII. Optical Characteristics

The following optical characteristics are defined over the Recommended Operating Environment unless otherwise specified.

Parameter	Symbol	Min.	Typical	Max	Unit	Notes
<b>Transmitter</b>						
Lane wavelength (range)	L0	1294.53	1295.56	1296.59	nm	
	L1	1299.02	1300.05	1301.09	nm	
	L2	1303.54	1304.58	1305.63	nm	
	L3	1308.09	1309.14	1310.09	nm	
Signaling rate, each lane			25.78125		GBd	
Side-mode suppression ratio	SMSR	30				
Total launch power	P <sub>T</sub>			10.5	dBm	
Average launch power, each lane	P <sub>avg</sub>	-2.9		4.5	dBm	
OMA, each Lane	P <sub>OMA</sub>	0.1		4.5	dBm	
Extinction Ratio	ER	4			dB	
Difference in Launch Power between any Two Lanes (OMA)	P <sub>tx,diff</sub>			3.6	dB	
Transmitter and Dispersion Penalty, each lane	TDP			2.5	dB	
OMA minus TDP, each lane	OMA-TDP	-0.65			dBm	
Average launch power of OFF transmitter, each lane	P <sub>off</sub>			-30	dBm	
Transmitter reflectance	R <sub>T</sub>			-12	dB	
RIN <sub>20OMA</sub>	RIN			-130	dB/Hz	
Optical Return Loss Tolerance	ORLT			20	dB	
Transmitter eye mask {X1,		{0.25, 0.4, 0.45, 0.25, 0.28, 0.4}				

X2,X3, Y1, Y2, Y3}						
<b>Receiver</b>						
Signaling rate, each lane			25.78125		GBd	
Average Receive Power, each Lane		-20		-4.9	dBm	
Receive Power (OMA), each Lane				-4.9	dBm	
Receiver Sensitivity (OMA), each Lane	SEN1			-14.65	dBm	BER = $1 \times 10^{-12}$
Receiver Sensitivity (OMA), each Lane	SEN2			-18.65	dBm	BER = $5 \times 10^{-5}$
Receiver reflectance				-26	dB	
Difference in Receive Power between any Two Lanes (Average and OMA)	Ptx,diff			3.6	dB	
LOS Assert	LOSA	-35			dBm	
LOS Deassert	LOSD			-20	dBm	
LOS Hysteresis	LOSH	0.5			dB	

## VIII. Digital Diagnostic Functions

The following digital diagnostic characteristics are defined over the normal operating conditions unless otherwise specified.

Parameter	Symbol	Min.	Max	Unit	Range
Temperature monitor absolute error	DMI_Temp	-3	3	°C	0~85C
Supply voltage monitor absolute error	DMI_VCC	-3	3	%	0~Vcc
RX power monitor absolute error	DMI_RX	-3	3	dB	-5~-20dBm
Bias current monitor error	DMI_bias	-10	10	%	0~100mA
TX power monitor absolute error	DMI_TX	-3	3	dB	-2.9~4.5dBm

## IX. Mechanical Dimensions

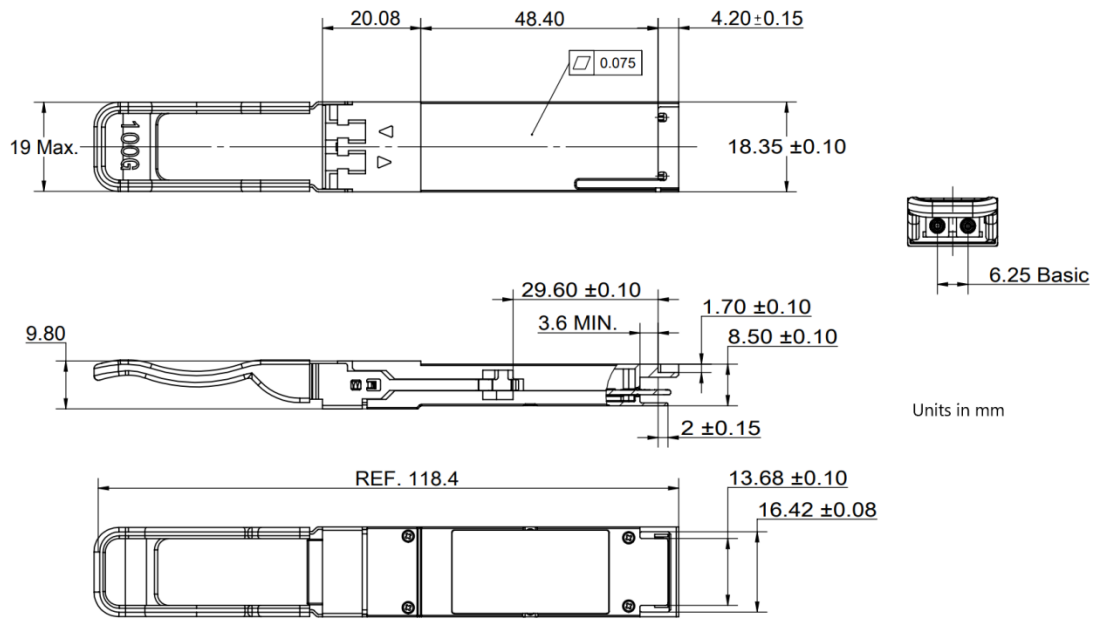

Figure2. Mechanical Outline

## X. Revision History

Version No.	Initiated	Revised contents	Release Date
V1.0	Andy Zhang	Preliminary datasheet	2018-09-20

## XI. Contact us

### SHENZHEN FB-LINK TECHNOLOGY CO.,LTD

Building B, Yuanchuang Park, No. 4,Henglang community, Dalang street, Longhua District, Shenzhen

T. +86 13631442493

PC. 518108

E. Jason@fb-link8.com

H. www.100gmodule.com